

NISSAN FRONTIER DEUCE 2

These instructions replace steps 1, 2, and 3 in the Deuce 2 owners manual.

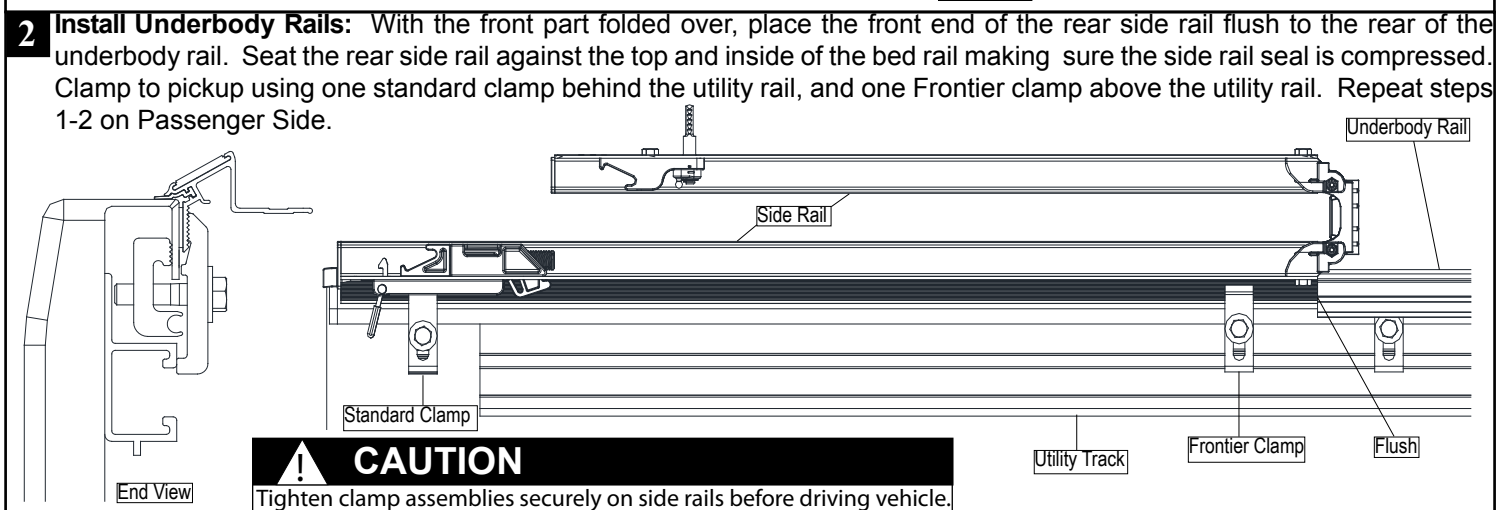
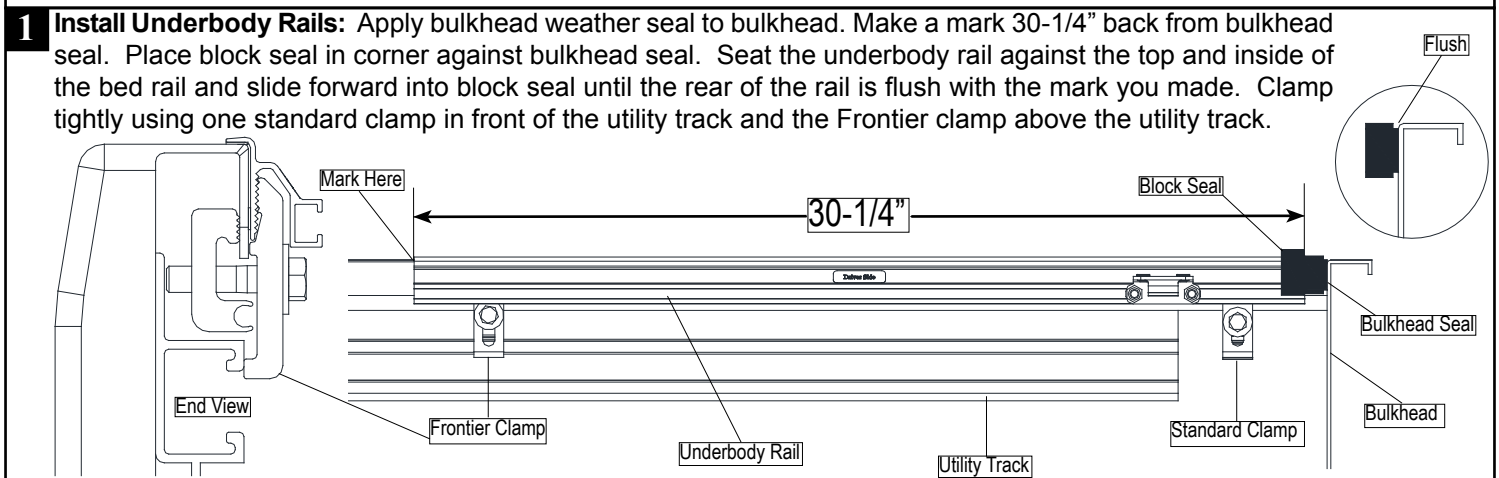
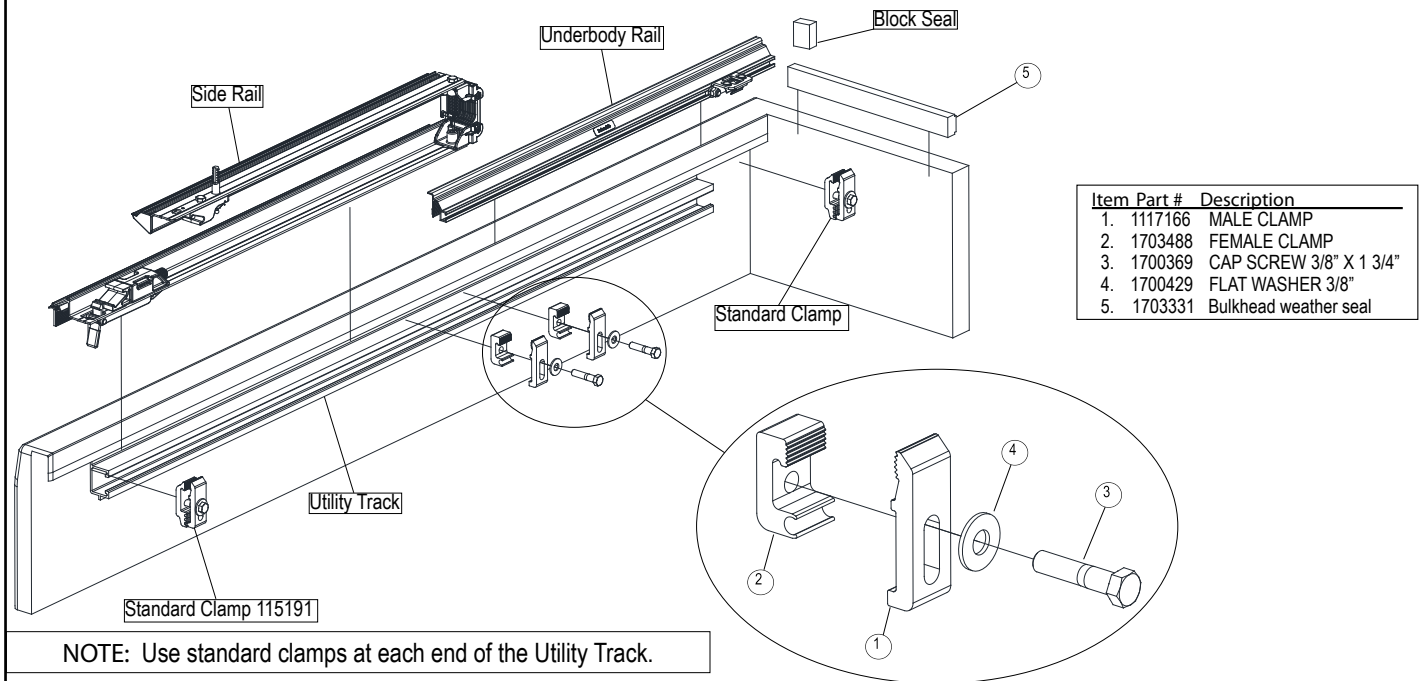

To finish installation, continue with step 4 in the Deuce 2 manual.

by TruXedo, Inc.

P.O. Box 1078, 2209 Kellen Gross Dr., Yankton, SD 57078

Phone: 877- 878-9336 • Fax: (605) 664-9304 www.truxedo.com

DEUCE 2 IS BETTER THAN 1